

VACUUM PUMP

LINEAR

VP0660



MOTOR FREE
PISTON SYSTEM



Airflow & Power Consumption

Specifications

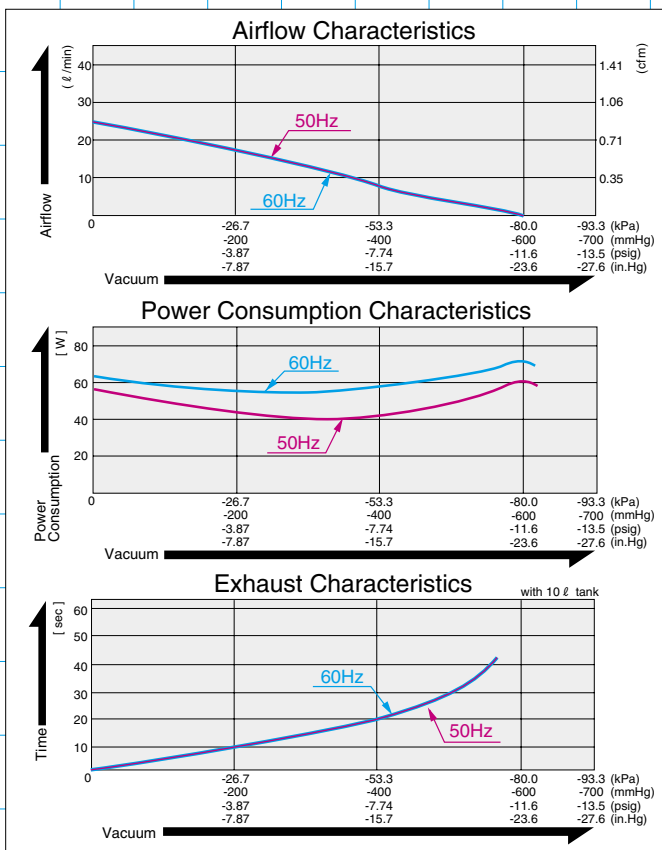

	(SI)	(EURO)	(U.S.A.)
Attainable Vacuum	-80 kPa (-600 mmHg)	-800 mbar	-23.6 in.Hg
Free Air Displacement	25 l/min		0.88 cfm
Rated Voltage	115 V AC or 230 V AC		
Power Consumption	70 W or 60 W		
Rated Frequency	60 Hz or 50 Hz		
Life Expectancy	6,000 hours		
Inlet	ISO Rc 1/4 (female threaded)		
Outlet	ISO Rc 1/4 (female threaded)		
Duty Cycle	Continuous		
Coil Insulation Class	E or its equivalent (JETL) or B for UL		
Mounting Dimensions	102 (L) x 130 (W) mm	4" (L) x 5-1/8" (W)	
Gross Weight	5 kg	11 Lbs.	
Leadwire Length	300 mm or 600 mm	5-7/8"	

Please read the page of "How to Use This Catalog" first for correct use of compressors and pumps.
*Operations at higher than -80kPa need an additional leak valve or relief valve on the inlet piping.

Application Examples

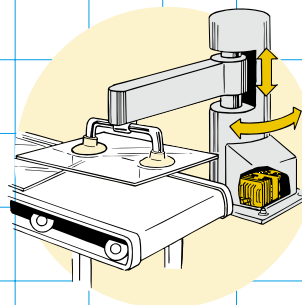

Material Handling Machine

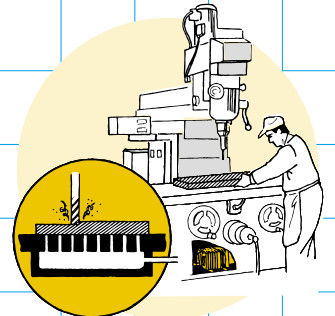

Vacuum Chucking

Sketch Drawing and Mounting Dimensions Diagram (mm)

